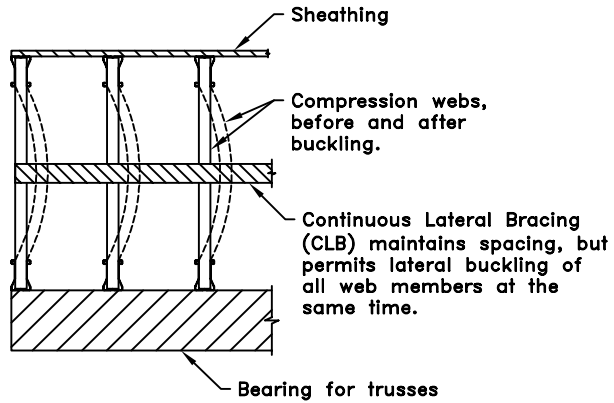


**THIS IS A DANGEROUS CONDITION**



**Fig. 1**



To prevent this failure, anchor or restrain the lateral bracing!

Use method shown in Fig. 2, 3A & 3B, or another structurally sound method specified by professional engineer.

NOTE: Truss spacing is 4'0" (1219mm) O.C. maximum.

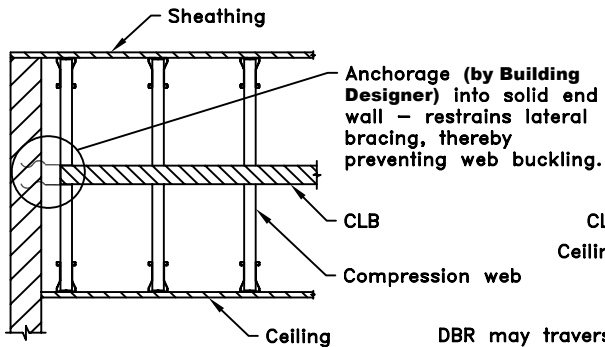
NOTE: Alpine recommends the CLB is to be 150F125-33 or 362S162-33 or equals. Attach to each web with (2) #10 self drilling sheet metal screws. See drawing TS019 for other details.

**Anchorage Or Restraint Of Lateral Bracing**

The drawing below shows how to restrain the continuous lateral bracing (CLB - ) needed in trusses (drawing shows example trusses with flat bottom chords). The diagonal brace restraint (DBR - ) members and it's connections are to be designed by a professional engineer. The ends are attached to top & bottom chords. The diagonal brace may be attached to the CLB or the web opposite the CLB.

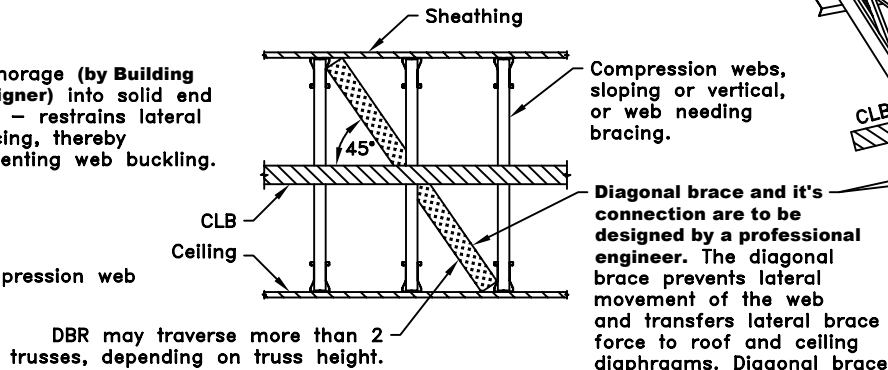
**Fig. 2**

**Anchorage by Building Designer**  
(other anchorage provisions for other types of walls).

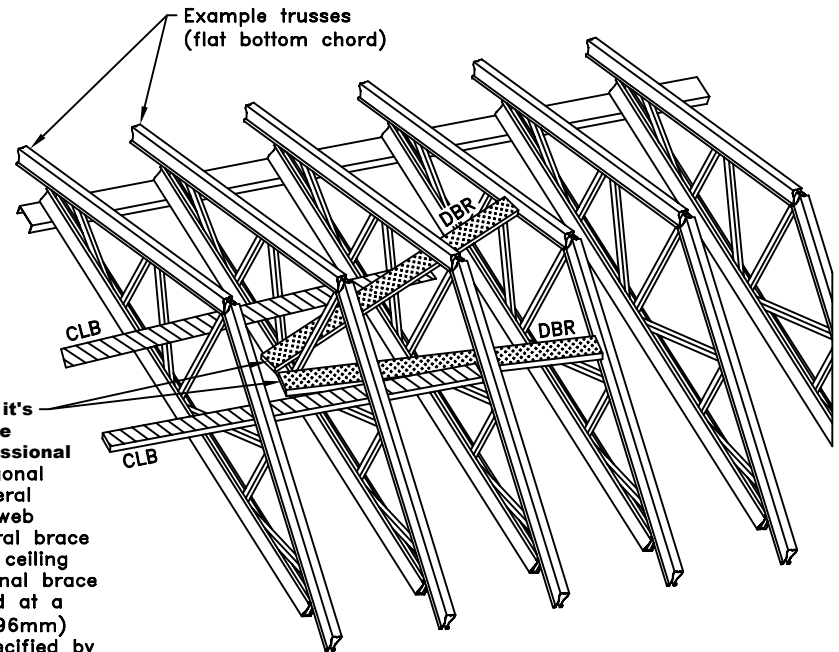


**Fig. 3A**

**Diagonal Brace Restraint (DBR)**  
within the unit (3A & 3B)



**FIG. 3B**

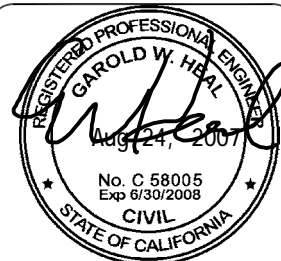


[www.TrusSteel.com](http://www.TrusSteel.com)

Florida: 1950 Marley Drive / Haines City, FL 33844 / (800) 755-6001  
Missouri: 13389 Lakefront Drive / Earth City, MO 63045 / (800) 326-4102  
California: 8351 Rovana Circle / Sacramento, CA 95828 / (800) 877-3678

**Web CLB Restraint**

ITW Building Components Group, Inc. shall not be responsible for any performance failure in a connection due to a deviation from this detail. Any variation from this detail shall be approved in advance by ITW Building Components Group, Inc.



Standard Detail:

TS017

Date:

03/08/07

TrusSteel Detail Category:

Bracing