

TS6WTC3

Maximum Uplift Capacity lbs. (kN)

| Chord Size/Gauge | Clip on one face | Clip on each face |
|------------------|------------------|-------------------|
| 28TSC2.75 - 22g | 550 (2.45) | 1640 (7.30) |
| 33TSC2.75 - 20g | 550 (2.45) | 2040 (9.07) |
| 43TSC2.75 - 18g | 550 (2.45) | 3040 (13.52) |
| 28TSC4.00 - 22g | 820 (3.65) | 1640 (7.30) |
| 33TSC4.00 - 20g | 1020 (4.54) | 2040 (9.07) |
| 43TSC4.00 - 18g | 1410 (6.27) | 3040 (13.52) |
| 54TSC4.00 - 16g | 1410 (6.27) | 3490 (15.52) |
| 68TSC4.00 - 14g | 1410 (6.27) | 3490 (15.52) |
| 97TSC4.00 - 12g | 1410 (6.27) | 3490 (15.52) |

TS1WTC3

Maximum Uplift Capacity lbs. (kN)

| Chord Size/Gauge | Clip on one face | Clip on each face |
|------------------|------------------|-------------------|
| 28TSC2.75 - 22g | 550 (2.45) | 1640 (7.30) |
| 33TSC2.75 - 20g | 550 (2.45) | 2040 (9.07) |
| 43TSC2.75 - 18g | 550 (2.45) | 3040 (13.52) |
| 28TSC4.00 - 22g | 820 (3.65) | 1640 (7.30) |
| 33TSC4.00 - 20g | 1020 (4.54) | 2040 (9.07) |
| 43TSC4.00 - 18g | 1410 (6.27) | 3040 (13.52) |
| 54TSC4.00 - 16g | 1410 (6.27) | 4180 (18.60) |
| 68TSC4.00 - 14g | 1410 (6.27) | 4180 (18.60) |
| 97TSC4.00 - 12g | 1410 (6.27) | 4180 (18.60) |

TS6WTC3 or
TS1WTC3

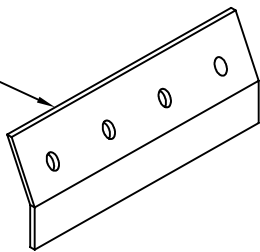

TS6WTC3 is 16g - base metal thickness (t) = 0.0538 in. (1.37mm)
TS1WTC3 is 10g - base metal thickness (t) = 0.128 in. (3.25mm)

Minimum top plate
bare metal thickness
is t = 0.0538"
(1.37mm)

TS6WTC3 or
TS1WTC3

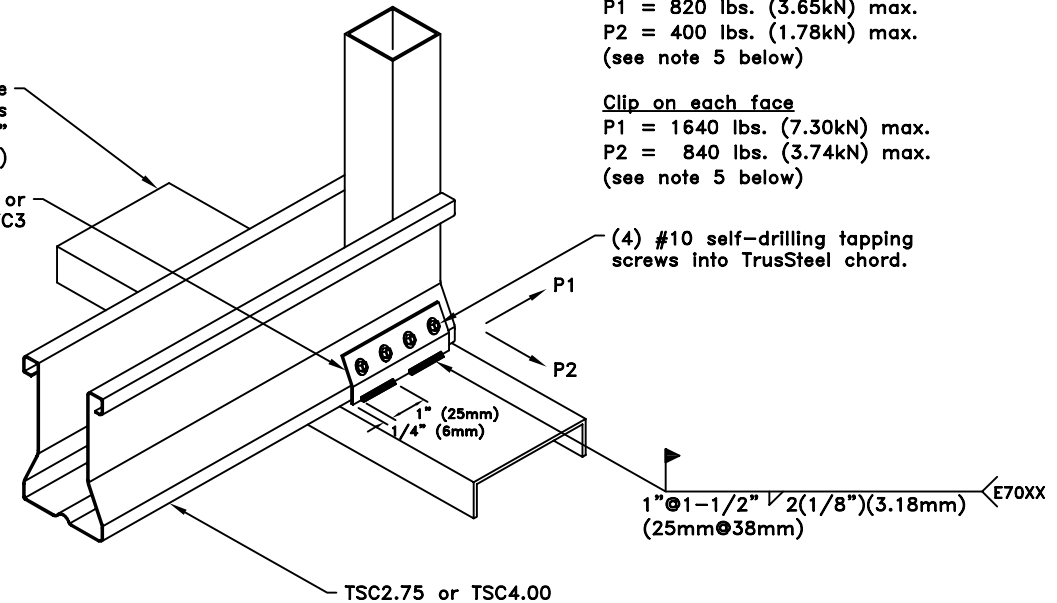

Maximum Allowable Lateral Loads

Clip on one face

P1 = 820 lbs. (3.65kN) max.
P2 = 400 lbs. (1.78kN) max.
(see note 5 below)

Clip on each face

P1 = 1640 lbs. (7.30kN) max.
P2 = 840 lbs. (3.74kN) max.
(see note 5 below)

(4) #10 self-drilling tapping
screws into TrusSteel chord.

General Notes:

1. Wall top plate is made of ASTM A653-96 SS grade 33 or grade 50 steel. Top plate width is 3-5/8" (92mm) maximum.
2. Attachment of second clip on opposite face of chord is identical to what is detailed.
3. Connection of top plate to wall stud must be capable of transferring truss uplift load from wall top plate to wall stud.
4. The wall top plate is to be designed by the job engineer. The wall top plate must be designed to support the loads applied to it (downward, upward and lateral).
5. Lateral allowable loads (P1 and P2) shown are maximum values. If these loads are in combination with an uplift load, contact a TrusSteel engineer.
6. Refer to TrusSteel Technical Bulletin 98.10.05 titled "Repair of Galvanized Surfaces" to restore corrosion resistant properties of the connection after welding.
7. The allowable loads outlined in this detail have not been increased by 1.33.

 **TrusSteel**[®]
Division of ITW Building Components Group, Inc.

www.TrusSteel.com

Florida: 1950 Marley Drive / Haines City, FL 33844 / (800) 755-6001
Missouri: 13389 Lakefront Drive / Earth City, MO 63045 / (800) 326-4102
California: 8351 Rovana Circle / Sacramento, CA 95828 / (800) 877-3678

TS6WTC3 or TS1WTC3
Welded Truss Clip
to Cold-Formed Steel

ITW Building Components Group, Inc. shall not be responsible for any performance failure in a connection due to a deviation from this detail. Any variation from this detail shall be approved in advance by ITW Building Components Group, Inc.

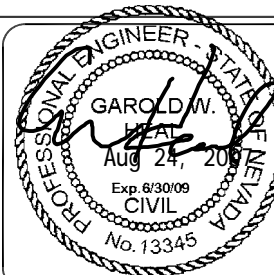

Standard Detail:

TS027B

Date:

06/04/07

TrusSteel Detail Category:

Truss-To-Bearing: All Other Materials