

Sprinkler Pipe Dia. in. (mm)	Maximum Allowable Hanger Load lbs. (kN)
2 (51)	640 (2.85)
4 (102)	1480 (6.58)
6 (152)	2630 (11.70)
8 (203)	4060 (18.06)

- Allowable hanger loads based on 15' (4572mm) hanger spacing.

Sprinkler Pipe Dia. in. (mm)	Threaded Rod Dia. in. (mm)	A36 Plate Thickness in. (mm)	A36 Steel Angle
2 (51)	3/8 (10)	1/8 (3.18)	L2-1/2x2x3/16
4 (102)	3/8 (10)	1/4 (6.35)	L2-1/2x2x3/16
6 (152)	1/2 (13)	3/16 (4.76)	L2-1/2x2x3/16
8 (203)	5/8 (16)	3/8 (9.53)	L2-1/2x2x3/16

- Refer to ASTM A6 for metric angle sizes.

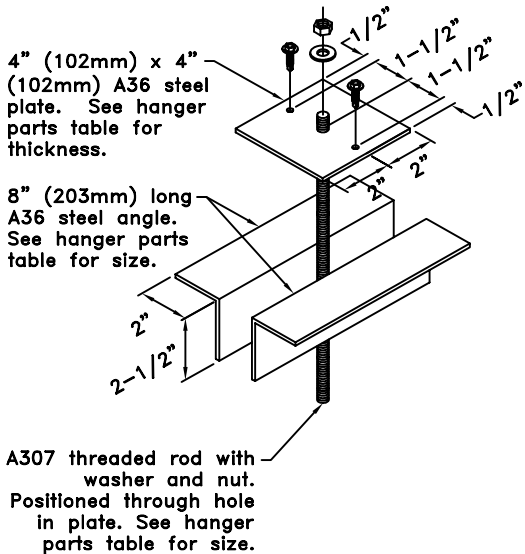

Note: Multiply above units by 25.4 for millimeters.

General Notes:

1. SDS = self-drilling tapping screw
2. Screw spacing and end distance is 3/4" (19mm).
3. This detail is only for the design of the sprinkler pipe hanger. Contact a TrusSteel engineer for the proper truss loading procedures.
4. It is the responsibility of the architect or engineer of record to review this hanger design to verify it conforms with the overall sprinkler system support design.
5. Allowable hanger load determined from the National Fire Protection Association NFPA13 titled "Installation of Sprinkler Systems".
6. Maximum sprinkler pipe size that can be supported by this detail is 8" (203mm) in diameter.
7. Pipe weight determined using schedule 40 steel pipe.
8. Pipe hanger spacing not to exceed 12' (3658mm) for pipes up to and including 1-1/4" (32mm) diameter and 15' (4572mm) for pipes greater than 1-1/4" (32mm) diameter per NFPA13.

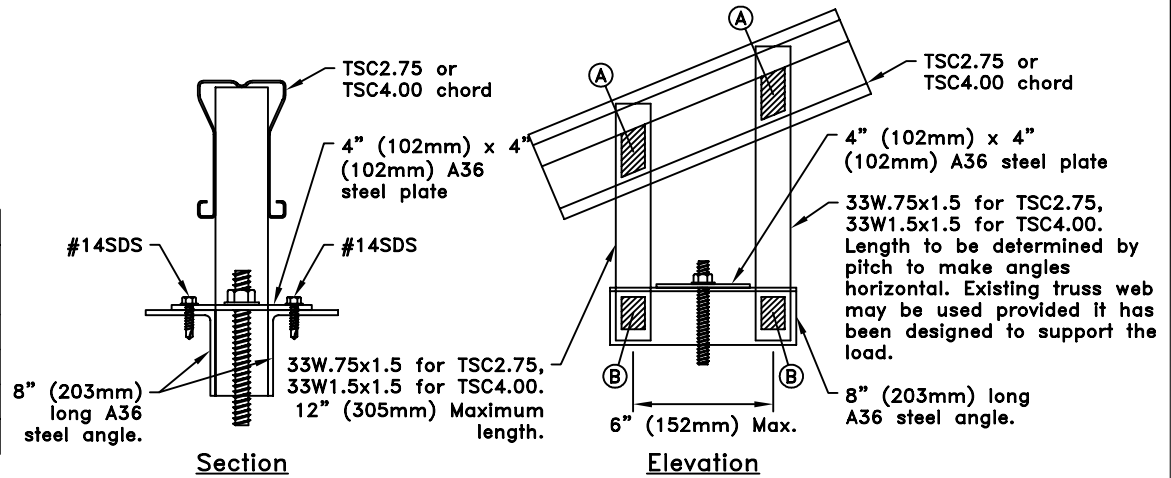

Sprinkler Pipe Dia. in. (mm)	Screws	
	(A)	(B)
2 (51)	2	2
4 (102)	2	2
6 (152)	3	3
8 (203)	4	4

Sprinkler Pipe Dia. in. (mm)	Fasteners	
	(A)	(B)
2 (51)	2	2
4 (102)	2	2
6 (152)	2	3
8 (203)	3	4

- Screws to be placed on each face of chord and hanger assembly.

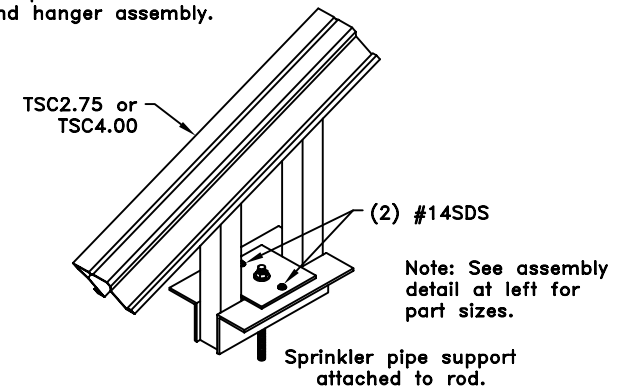

www.TrusSteel.com

Florida: 1950 Marley Drive / Haines City, FL 33844 / (800) 755-6001
 Missouri: 13389 Lakefront Drive / Earth City, MO 63045 / (800) 326-4102
 California: 8351 Rovana Circle / Sacramento, CA 95828 / (800) 877-3678

Top Chord Sprinkler Pipe Hanger For 8" (203mm) Maximum Diameter Pipe

ITW Building Components Group, Inc. shall not be responsible for any performance failure in a connection due to a deviation from this detail. Any variation from this detail shall be approved in advance by ITW Building Components Group, Inc.

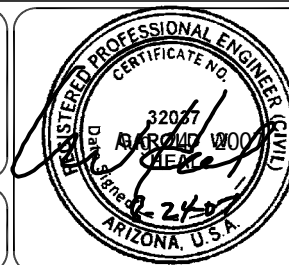

Standard Detail:
TS049B

Date:
06/04/07

TrusSteel Detail Category:
Sprinkler Pipe Hangers