

Hanger Loading Table  
6 in. (203mm) Maximum Diameter Pipe

Sprinkler Pipe Diameter in. (mm)	Maximum Allowable Hanger Load lbs. (kN)	Threaded Rod Dia. in. (mm)
6 (152)	2620 (11.65)	1/2 (13)
8 (203)	4020 (17.88)	1/2 (13)

\* Allowable hanger loads based on maximum hanger spacing. (see note 8)

TSC2.75 Truss top chords at 48" (1219mm) O.C. maximum.

33W1.5x2.0 TS tube vertical support posts. Minimum length to match chord depth plus trapeze.

(2)600S162-43 grade 50 trapeze member. Space at 15ft (4572mm) maximum. Each end to extend 1/4" (6mm) minimum beyond truss chord.

ASTM A307 threaded rod with washer and nut positioned between tube web stiffeners (see hanger rod assembly detail, this sheet) See hanger loading table for size.

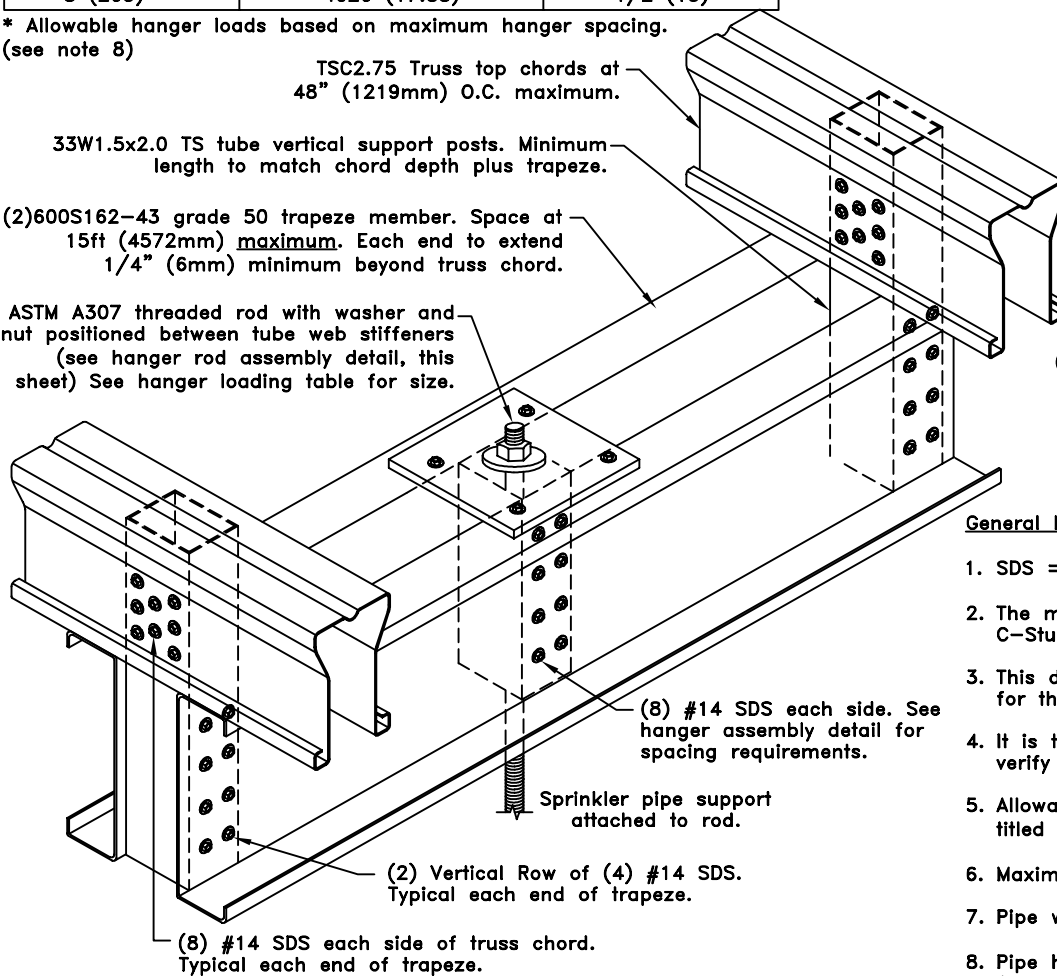

Note: Hanger rod assembly may be placed anywhere along the trapeze.

Attach plate to each C-stud w/ (2) #14 SDS.

4"x4"x3/8" ASTM A36 steel plate.

(2)600S162-43 grade 50 sprinkler pipe trapeze.

33W1.5x2.0 45ksi web stiffener at applied load. Length to match depth of trapeze.

ASTM A307 threaded rod with washer and nut at each end. Positioned through web stiffener and trapeze. See hanger loading table for size.

(8) #14 SDS each side at web stiffener. Maintain 3/4" (19mm) minimum vertical spacing and distance from end of stiffener and 7/8" (22mm) minimum horizontal spacing.

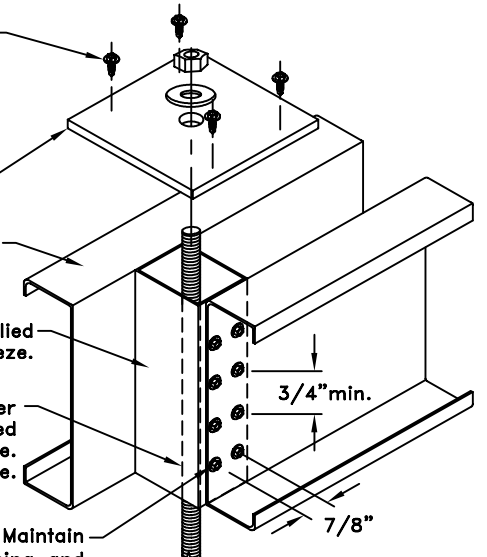

### Hanger Rod Assembly Detail

Note: Multiply above units by 25.4 for millimeters.

#### General Notes:

1. SDS = self-drilling tapping screw. Screw spacing, end and edge distance is 3/4" (19mm) min.
2. The minimum yield strengths of materials are as follows (unless otherwise noted):  
C-Stud Trapeze = 33ksi, Tube steel support posts = 45ksi, TrusSteel Chords = 55ksi.
3. This detail is only for the design of the sprinkler pipe hanger. Contact a TrusSteel engineer for the proper truss loading procedures.
4. It is the responsibility of the architect or engineer of record to review this hanger design to verify it conforms with the overall sprinkler system support design.
5. Allowable hanger load determined from the National Fire Protection Association NFPA13 1999 titled "Installation of Sprinkler Systems".
6. Maximum sprinkler pipe size that can be supported by this detail is 6" (152mm) in diameter.
7. Pipe weight determined using schedule 40 steel pipe.
8. Pipe hanger spacing not to exceed 12' (3658mm) for pipes up to and including 1-1/4" (32mm) diameter and 15' (4572mm) for pipes greater than 1-1/4" (32mm) diameter per NFPA13 1999.
9. Vertical truss web may be used as trapeze support post provided it is designed to carry additional sprinkler loads per proper truss loading procedures.



www.TrusSteel.com

Florida: 1950 Marley Drive / Haines City, FL 33844 / (800) 755-6001  
Missouri: 13389 Lakefront Drive / Earth City, MO 63045 / (800) 326-4102  
California: 8351 Rovana Circle / Sacramento, CA 95828 / (800) 877-3678

Double C-Stud Sprinkler Trapeze  
at TSC4.00 Top Chord for  
8" (203mm) Max. Diameter Pipe

ITW Building Components Group, Inc. shall not be responsible for any performance failure in a connection due to a deviation from this detail. Any variation from this detail shall be approved in advance by ITW Building Components Group, Inc.



Standard Detail:

TS049K

Date:

06/04/07

TrusSteel Detail Category:

Top Chord Sprinkler Hanger